

1-2. Bracket for wooden box *1set

 RAL6034
 #a35234



Catalog

1. Overall parts diagram.....	1
2. Front box size and packing list	2
3. Wooden bucket diagram and assembly process.....	3
Step 1: Installation of wooden board columns.....	4
Step 2: Installation of side and bottom plate corners.....	5
Step 3: Installation of seat plate stop block	6
Step 4: Installation of seat board	7
Step 5: Installation of seat belts	8
4. Rear box size and packing list	9
5. Bike diagram and assembly process.....	10
Step 1: Installation of steering stem and handlebar	11
Step 2: Installation of bottom frame and kickstand.....	12
Step 3: Installation of the front wheels	13
Step 4: Installation of left and right steering rod	14
Step 5: Installation of display, bell, seat cushion and pedal	15
6. Wooden bucket and bike final assembly.....	16

1. Overall parts diagram

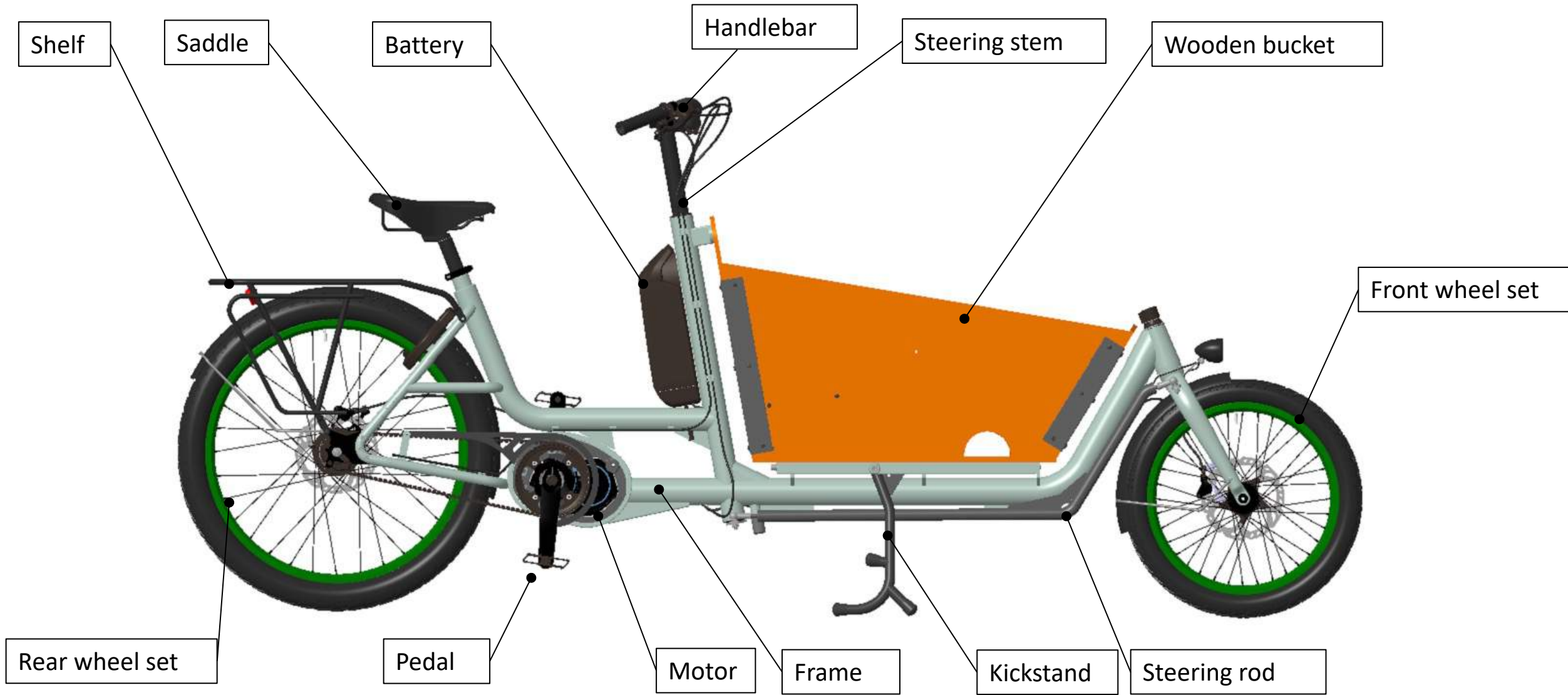

2. Front box size and packing list



Front carton size :
890L*100W*660H (Unit : mm)



3. Wooden bucket diagram and assembly process

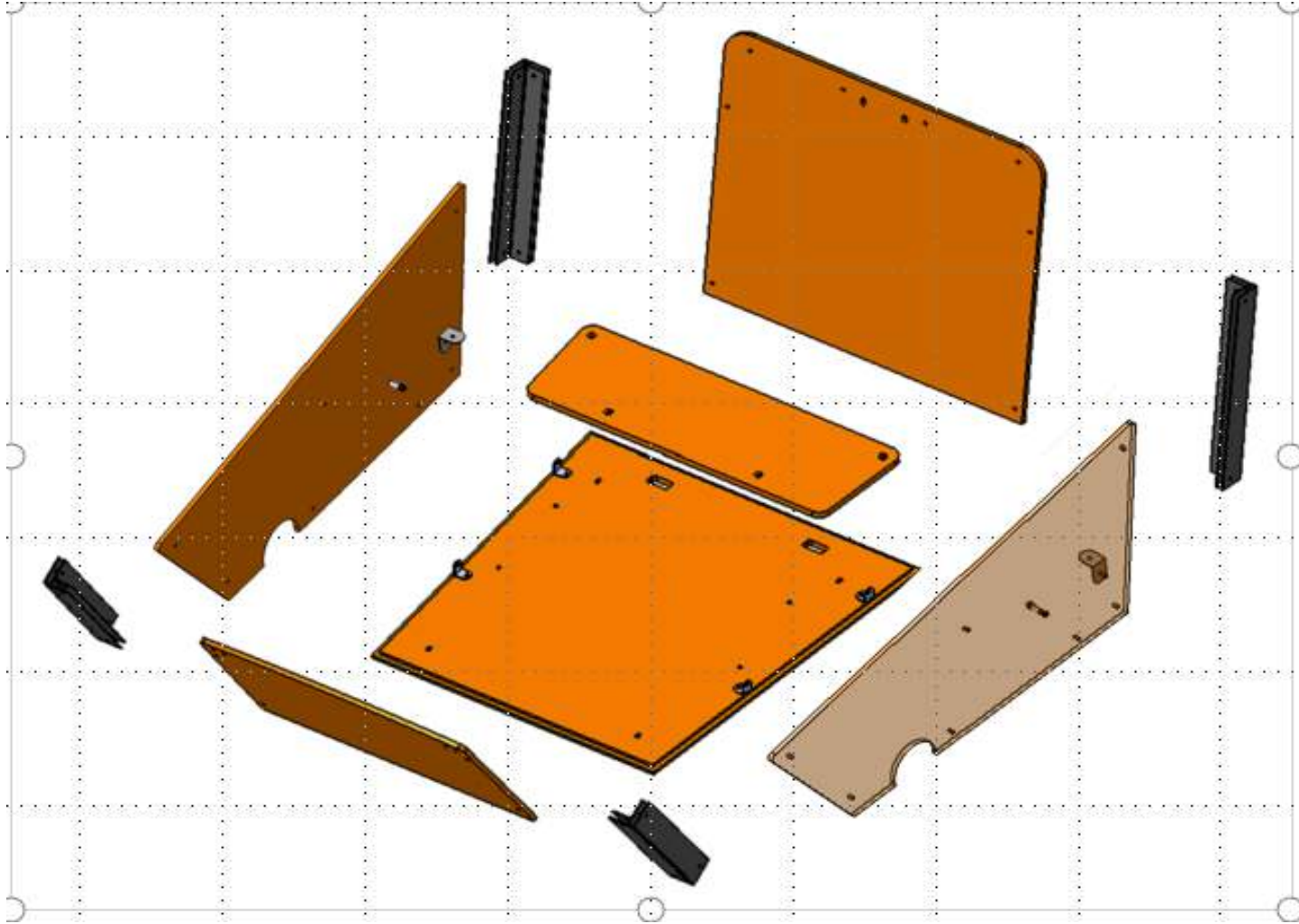

Steps	Details
Step 1	Installation of wooden board columns
Step 2	Installation of side and bottom plate corners
Step 3	Installation of seat plate stop block
Step 4	Installation of seat board
Step 5	Installation of seat belts



Step 1 : Installation of wooden board columns

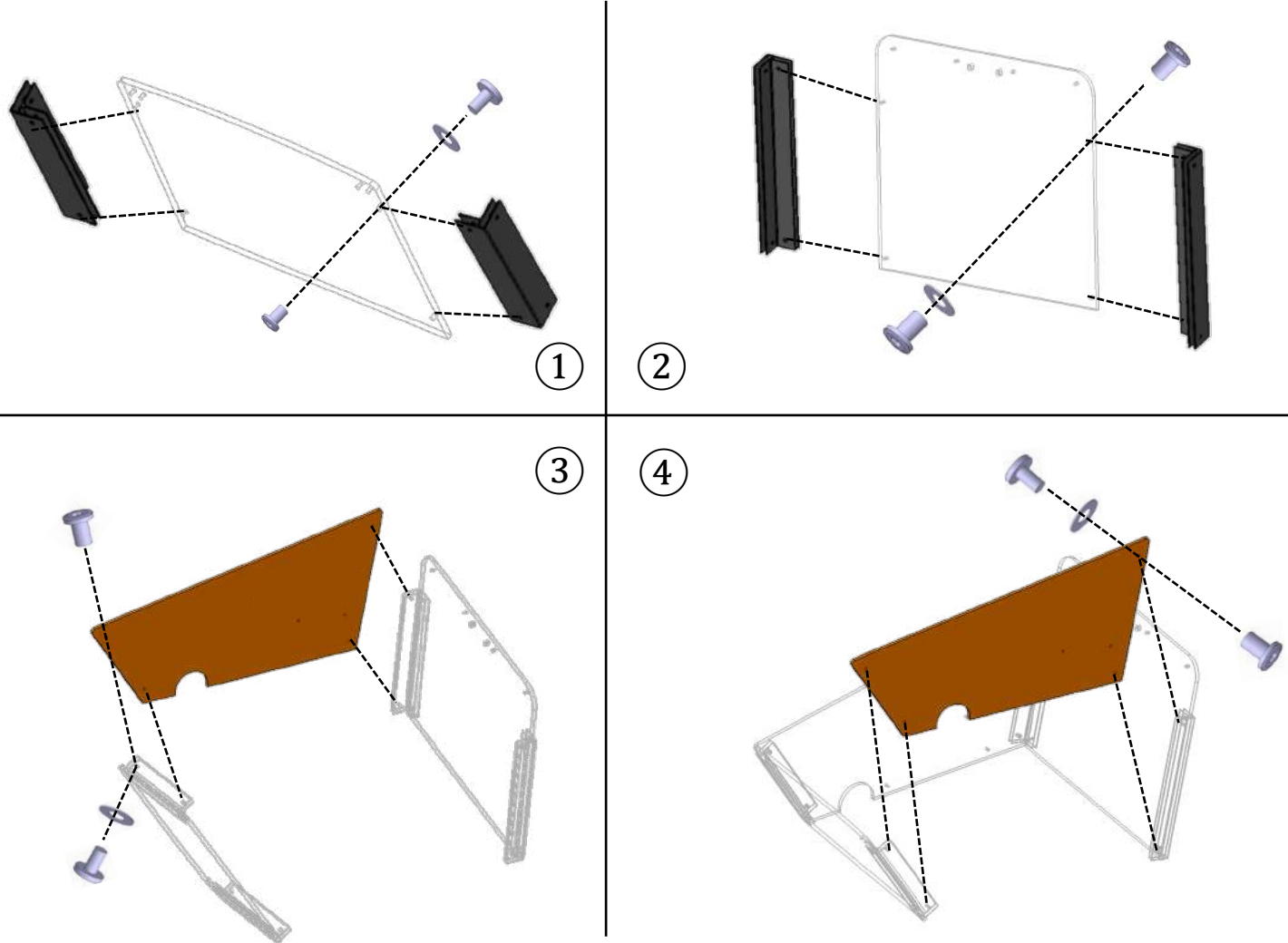

Step 1 standard parts list

Picture	Item	Qty
	Locking screws Φ6*12	16
	Gaskets Φ6*Φ12*2T	16



Step 2 : Installation of side and bottom plate corners

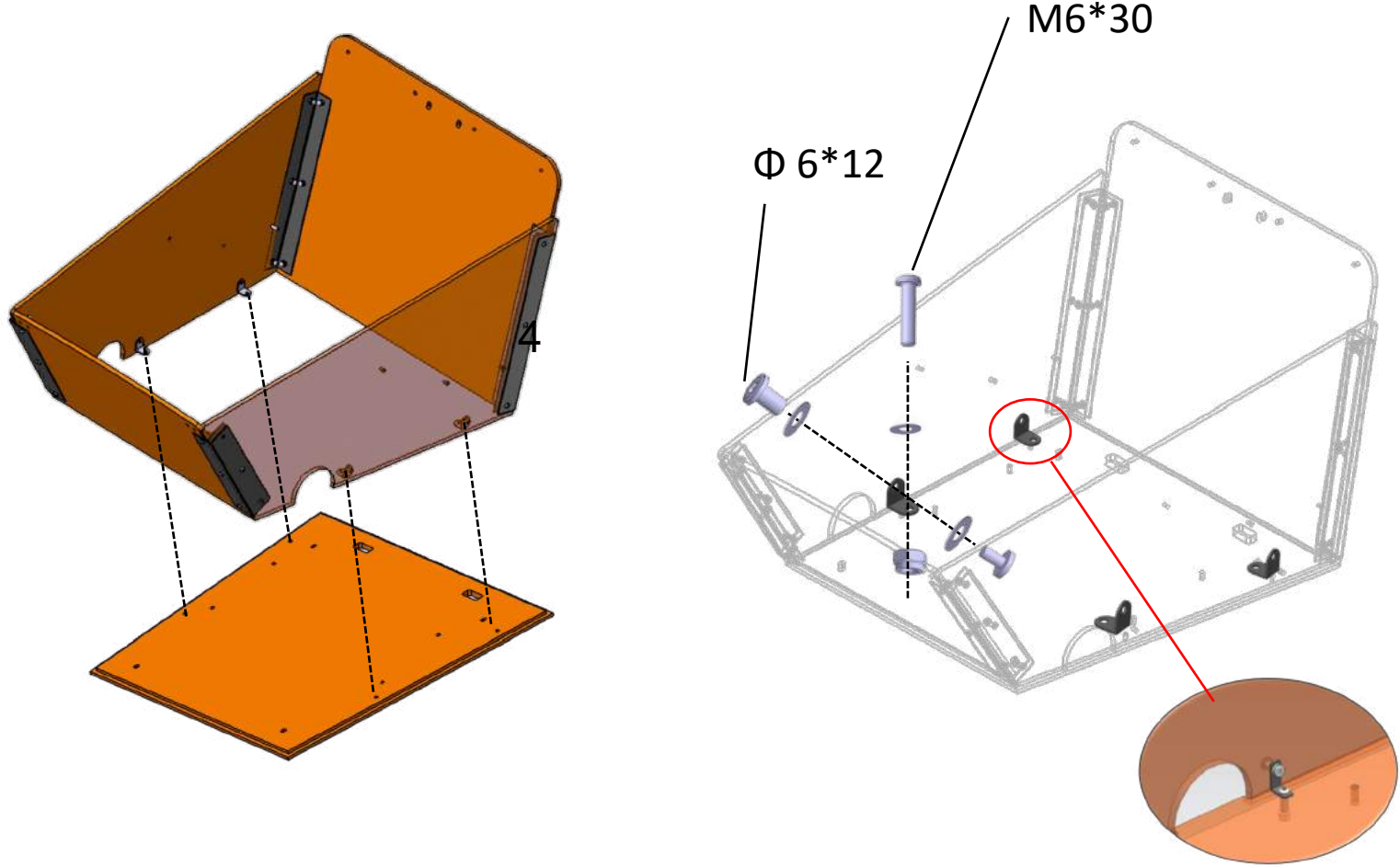

Step 2 standard parts list

Picture	Item	Qty
	Folding plate (Small size)	4
	Locking screws Φ6*12	4
	Gaskets Φ6*Φ12*2T	8
	Screws M6*30	4
	Gaskets Φ6	4
	Nuts M6 nylon Nuts	4

Step 3 : Installation of seat plate stop block

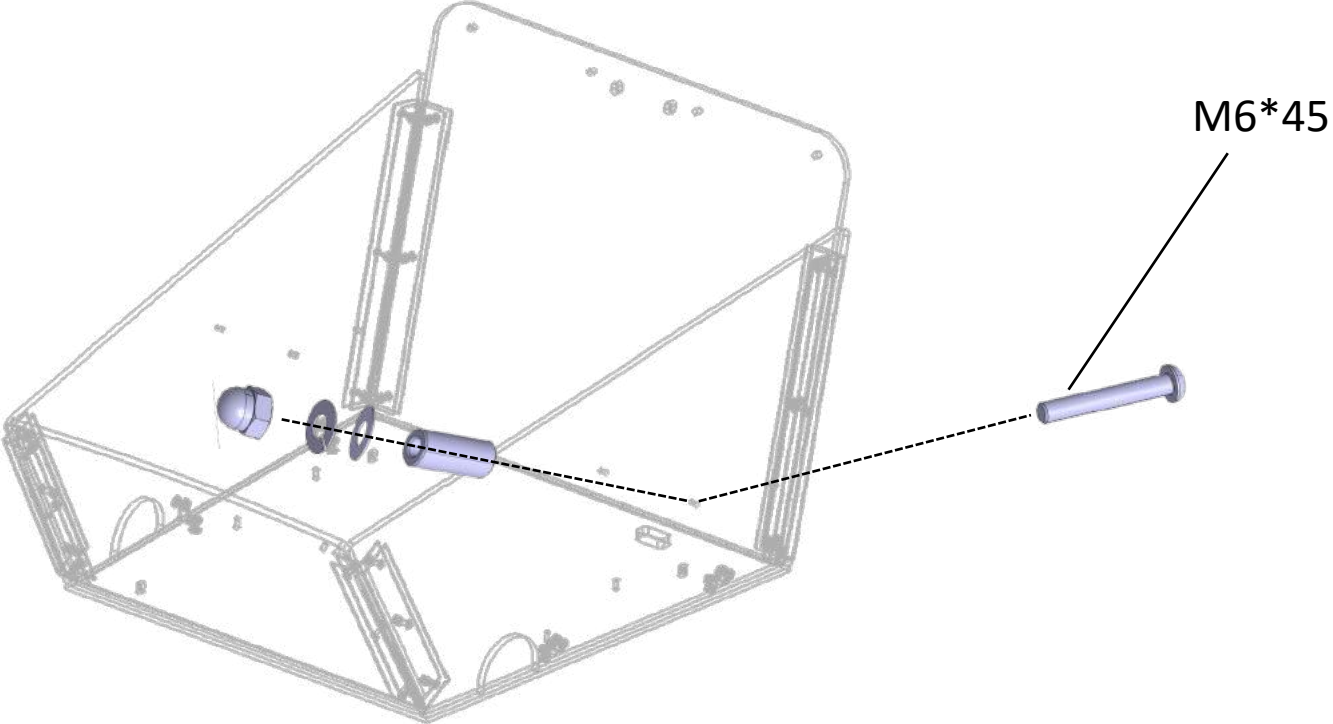

M6*45



Step 3 standard parts list

Picture	Item	Qty
	Bushing	2
	Screws M6*45	2
	Gaskets Φ6	2
	Spring gasket Φ6	2
	Nuts M6 Cap Nut	2

Step 4 : Installation of seat board

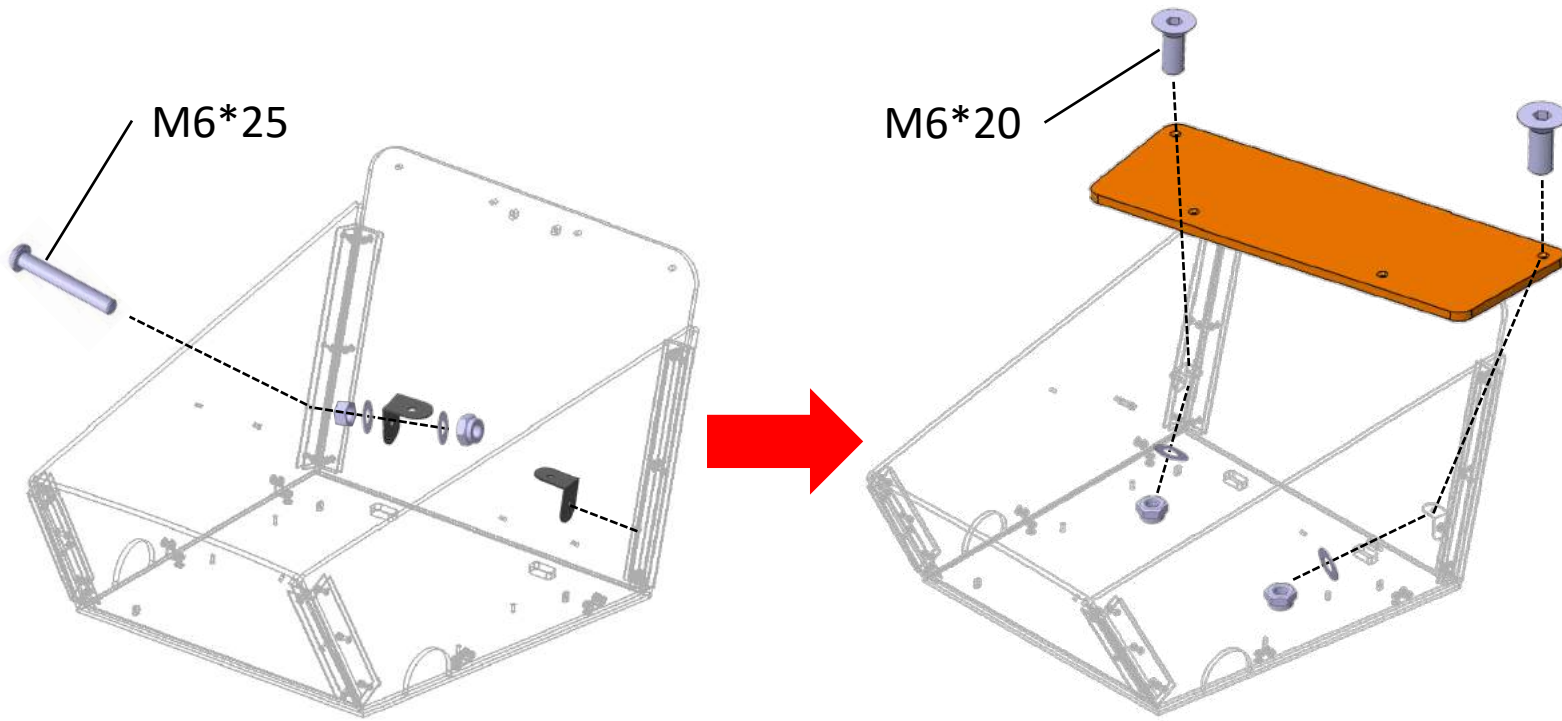

Step 4 standard parts list

Picture	Item	Qty
	Folding plate (Big size)	2
	Screws M6*25	2
	Nuts M6 Plain Nut	2
	Gaskets Φ6	4
	Nuts M6 nylon Nuts	2
	Screws M6*20	2
	Gaskets Φ6	2
	Nuts M6 nylon Nuts	2

Step 5 : Installation of seat belts









①. The seat belt is secured to the rear plate



②. The seat belt is fastened to the seat plate

Step 5 standard parts list

Picture	Item	Qty
	Screws M6*20	4
	Gaskets Φ6*Φ18	4
	Nuts M6 nylon Nuts	4
	Screws M6*20	2
	Gaskets Φ6*Φ18	2
	Nuts M6 nylon Nuts	2

4. Rear box size and packing list



Rear carton size :
2320L*230W*810H (Unit :mm)



Parts kit (Accessories box size: 550*220*700mm)



Display



Charger



Parts kit (Accessories box size: 220*130*270mm)

5. Bike diagram and assembly process



Steps	Details
Step 1	Installation of steering stem and handlebar
Step 2	Installation of bottom frame and kickstand
Step 3	Installation of the front wheels
Step 4	Installation of left and right steering rod
Step 5	Installation of display, bell, seat cushion and pedal

Step 1 : Installation of steering stem and handlebar

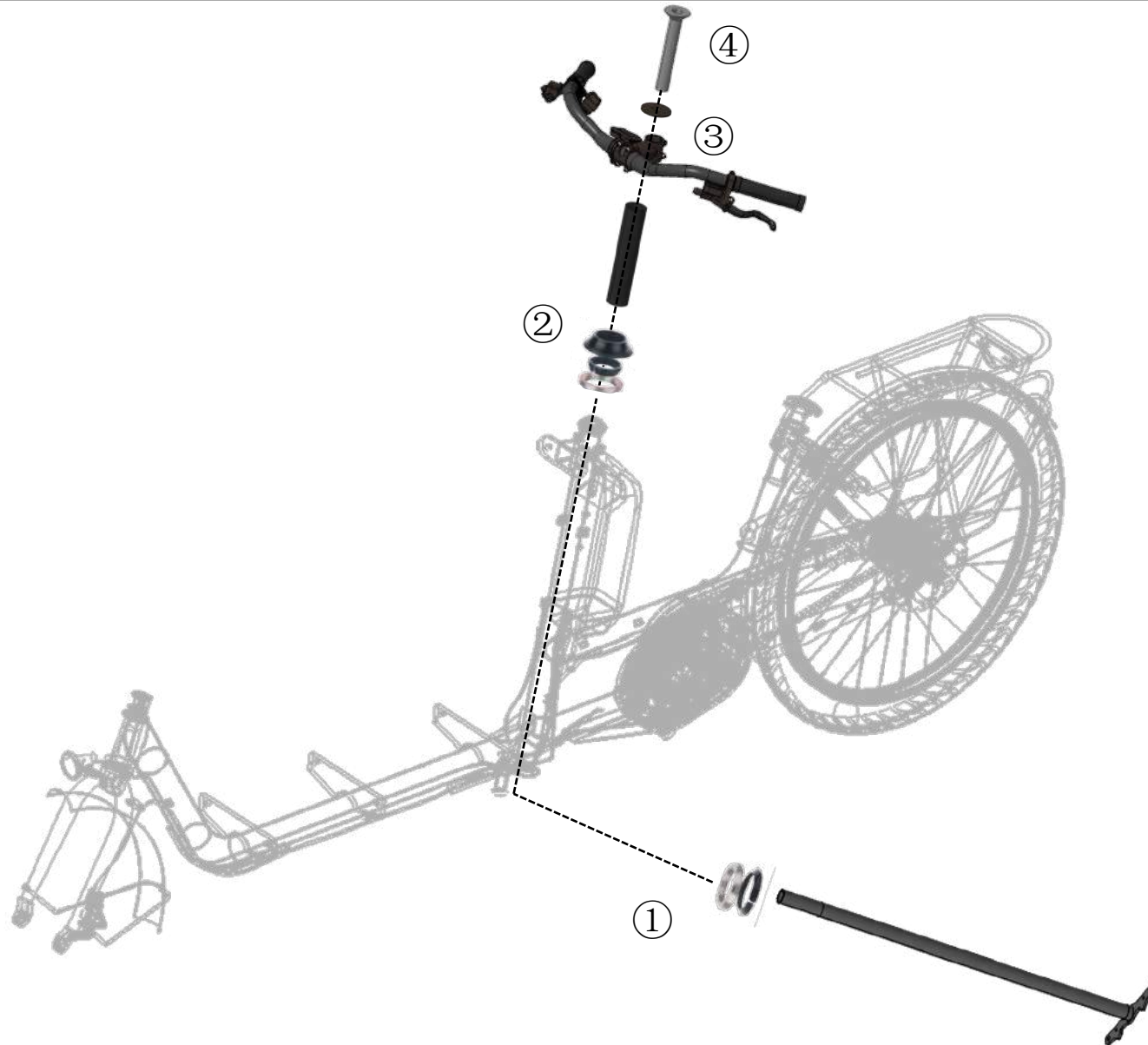

①. Place the first downshift at the very bottom of the rudder trunk and pass it underneath the frame.



②. Install upper file, upper cover, washer and bushing successively above.



③. Install the handlebars and uprights on the rudder trunk.



④. Finally install the lifting screws.

Step 2 : Installation of bottom frame and kickstand



Step 2 standard parts list

Picture	Item	Qty
	Screws M8*55	6
	Gaskets $\Phi 8$	12
	Nuts M8 nylon Nuts	6

Step 3 : Installation of the front wheels

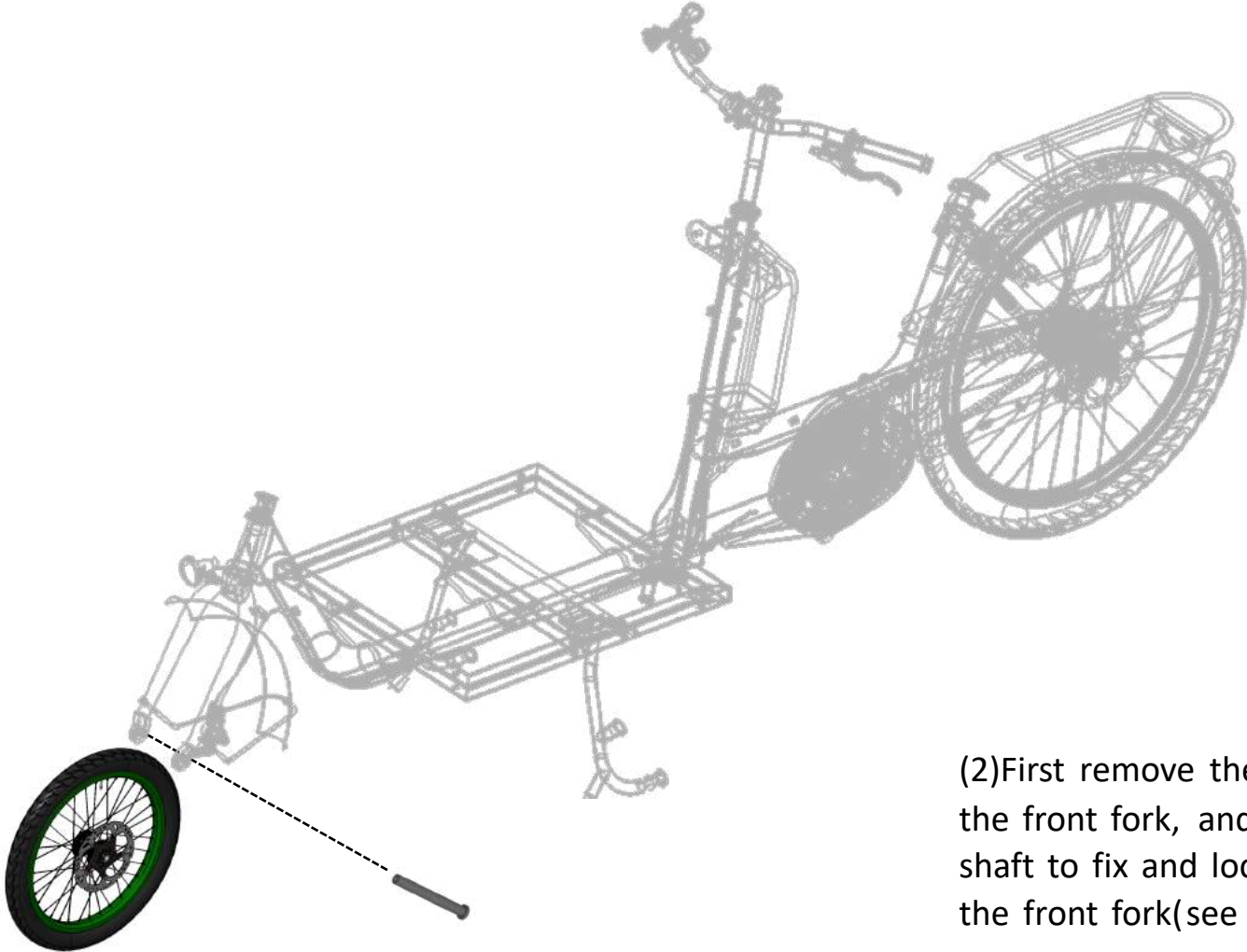

(1) First take out the insert in the front hydraulic disc brake (see figure).



(insert)



(2) First remove the barrel shaft from the front fork, and then use the barrel shaft to fix and lock the wheel set with the front fork (see figure).



Step 4 : Installation of left and right steering rod

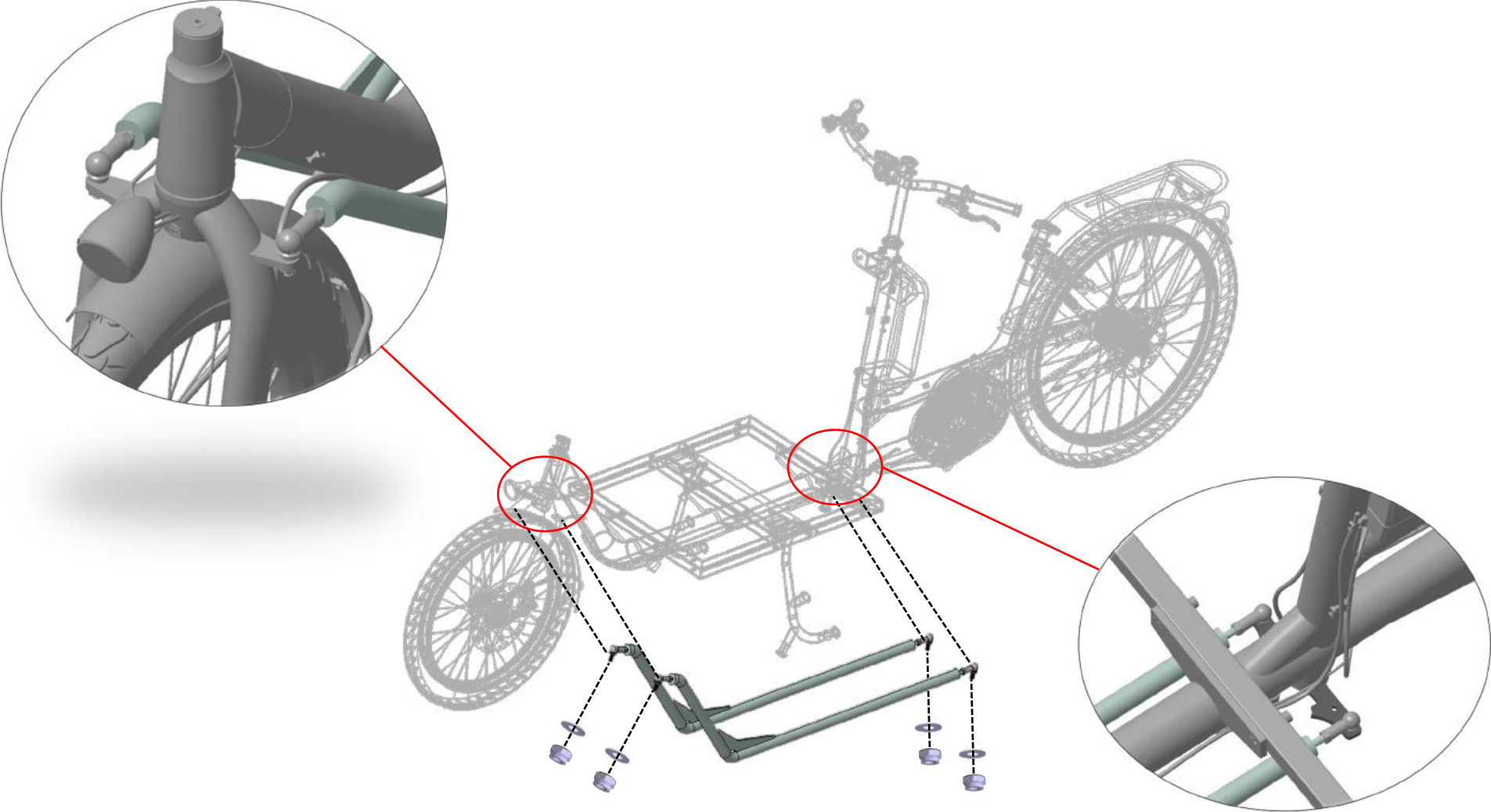

Step 5 : Installation of display, bell, seat cushion and pedal

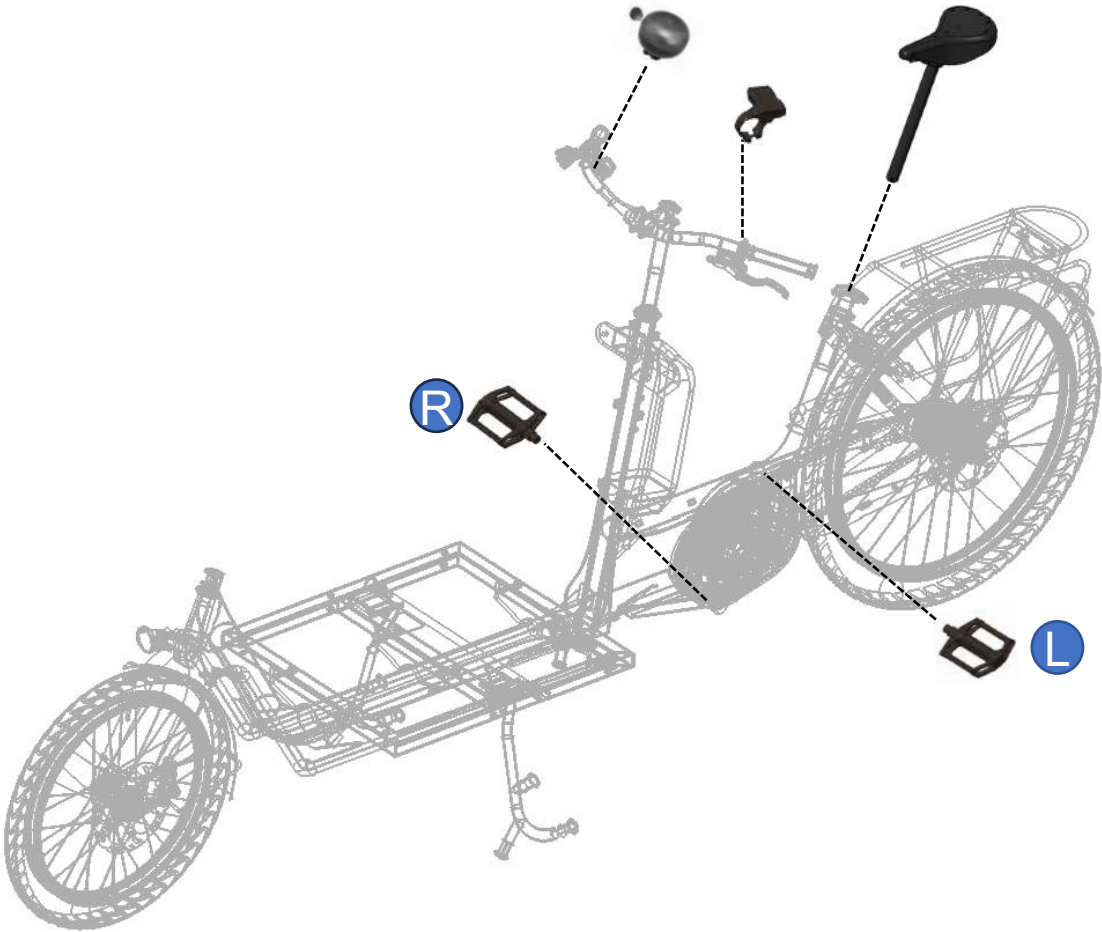

6. Wooden bucket and bike final assembly

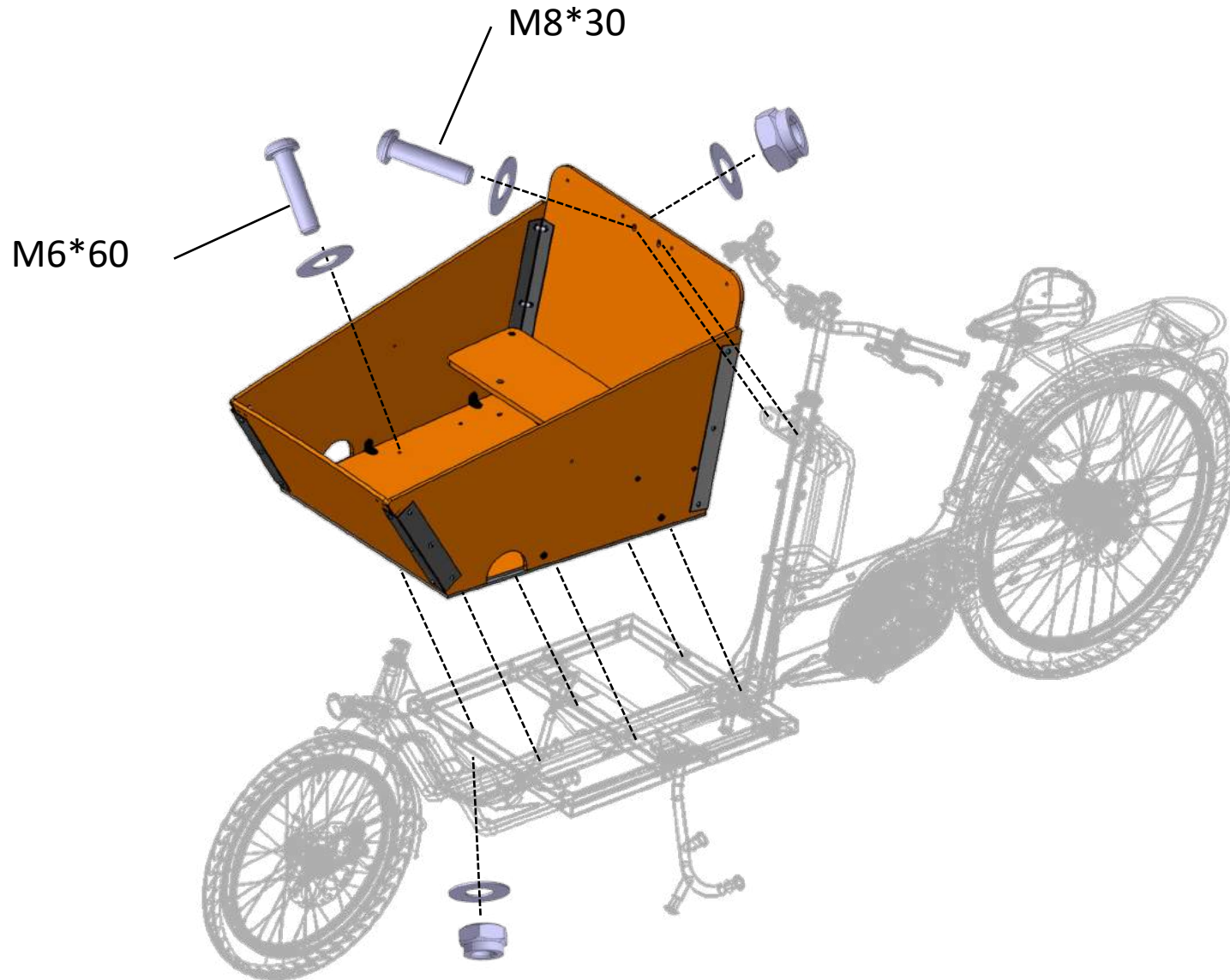

Standard parts list

Picture	Item	Qty
	Screws M6*60	6
	Gaskets Φ6	12
	Nuts M6 nylon Nuts	6
	Screws M8*30	2
	Gaskets Φ8	4
	Nuts M8 nylon Nuts	2

Congratulation, we hope you enjoy your new Cargobike

